

# User Manual

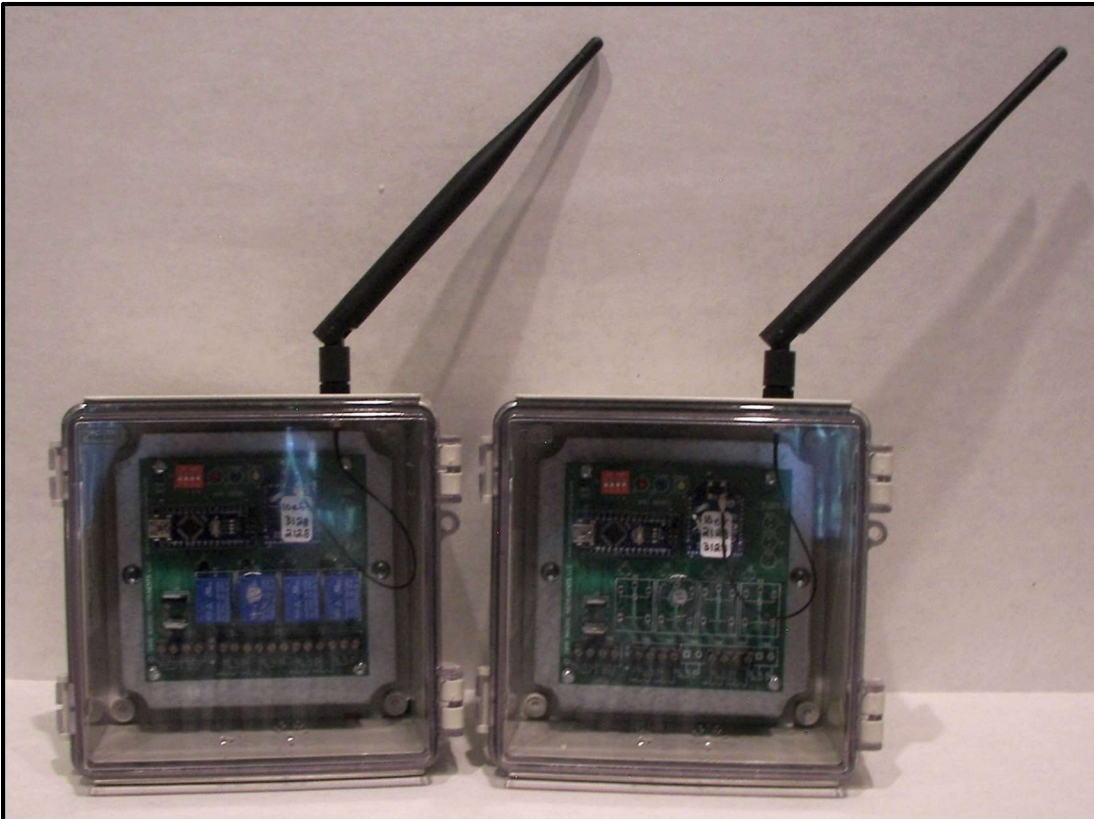

Series: WXL

## Wireless Remote-Control System

Imagine Instruments LLC, 4500 Williams Drive, Ste 212-318, Georgetown, TX 78633  
W: [www.ImagineInstruments.com](http://www.ImagineInstruments.com), P: (512) 778-6850, E: [info@imagineinstruments.com](mailto:info@imagineinstruments.com)

## Section 1 Before You Begin Using Your Unit

1.1	Symbols & Safety Information .....	4
1.2	Conditions of Use .....	5
1.3	Unpacking .....	5

## Section 2 Introduction

2.1	Product Description .....	5
2.2	Available Models .....	6
2.3	Optional Items .....	6

## Section 3 Specifications

3.1	Specifications .....	7
3.2	Environmental Operating Conditions .....	8
3.3	Regulatory Approvals & Export Compliance .....	8

## Section 4 Installation

4.1	General Guidance .....	9
4.2	Mounting and Area Environment .....	9
4.3	Antenna Installation Positioning .....	9
4.4	Connecting Your Antennas .....	10
4.5	Antenna Placement (Standard Oni Antennas) .....	10
4.6	Antenna Placement (Optional Yagi Antennas) .....	11

## Section 5 Transmitter/Receiver Features & Settings

5.1	Switch Transmitter Features .....	12
5.2	Relay Receiver Features .....	13

## Section 6 Setup & Wiring

6.1	Powering Your Unit .....	15
6.2	Power Supply Wiring .....	15

## Section 7 General Operation

7.1	Basic System Operation .....	16
7.2	Factory Settings .....	16

## Section 8 Installation & Setup

8.1	Connecting Switches To The Transmitter Board .....	17
8.2	Control Relay Output Board Connections .....	17
8.3	Signal Strength Indicator .....	17
8.4	RF Signal Loss Alarm Output .....	18

## Section 9 Maintenance

9.1	Maintenance .....	18
-----	-------------------	----

Section 10 Warranty & Liability

9.1 Warranty/Product Returns ..... 18  
9.2 Limitation of Liability ..... 18

Section 11 Service

11.1 Repair & Service ..... 19  
11.2 Contact Information ..... 19

List of Figures

	Page
Figure 1. The Fresnel Zone .....	9
Figure 2. Vertical Omni Antenna Example .....	10
Figure 3. Horizontal Yagi Antenna Example .....	11
Figure 4. Switch Transmitter Board Features .....	12
Figure 5. Relay Receiver Board Features .....	13
Figure 6. TB1 Power Connection .....	14
Figure 7. Switch Connections .....	15
Figure 8. Relay Output Connections .....	15
Figure 9. RF Signal Meter .....	15
Figure 10. Alarm Connection .....	15

# Section 1 Before You Install and Use Your Equipment

## 1.1 Symbols & Safety Information

Listed below are the International Symbols used on the product, or in this manual.



Danger: Electric Shock Hazard



Warning: Refer to Documentation and this User Guide

### General Safety Guidelines

- Follow all safety guidelines outlined in this guide and/or marked on the unit.
- Never install or operate this product outside the specifications listed in this guide.
- Never install and operate in flammable or explosive environments.
- Install your unit in a location that is out of the reach of unauthorized personnel.
- Always install additional disconnect and safety devices to provided added protection.
- Never operate this product outside the environmental limits specified in this guide.

### Electrical Safety Guidelines

- Never attempt maintenance or service while power is connected.
- Installation and all wiring should be done by a trained professional.

Note: Personnel entrusted with installation, setup and operation of this product must be suitably qualified and trained. The required knowledge and experience can be gained via training courses and appropriate on-the-job instruction. Personnel should have this document available to them at all times when working with this product.

### RF Safety Guidelines

- Only operate this product with the antenna provided or optional antennas listed in this guide.
- Never install and operate this product where there will always be people closer than 20 cm.
- Never operate multiple units within 20 cm or less from each other.
- Never operate other RF transmitters of the same frequency within 20 cm or less of this product.

## 1.2 Condition of Use

Imagine Instruments LLC products are not designed, intended or authorized for use in medical applications, applications intended to sustain or support life, in any nuclear facilities or any other application where the failure of the product could create a situation where catastrophic property damage, personal injury or death may occur. In the event that the Customer purchases or uses any Imagine Instruments LLC products for any such unintended or unauthorized application, the Customer shall indemnify and hold harmless Imagine Instruments LLC and its officers, directors, employees, agents, affiliates, successors and assigns against all claims, costs, damages and expenses (including reasonable attorneys' and expert witness' fees) arising out of or in connection with, directly or indirectly, any claim for property damage, personal injury or death associated with such unintended or unauthorized use, even if such claim alleges that Imagine Instruments LLC was negligent regarding the design or manufacture of the subject product.

## 1.3 Unpacking

Unpack your product carefully and inspect for any shipping damage. Notify the carrier immediately if you find damage.

The following items are included with your system:

- Two Antennas
- Two Antenna Extension Cables
- Switch Transmitter / Relay Receiver Set
- This User's Guide

## Section 2 Introduction

### 2.1 Product Description

The WXL Series Wireless Remote-Control System allows for remotely activating equipment from up to 1 mile for model WXL-24, or up to 6 miles for model WXL-900 using license free wireless radio communication. Units are equipped with contact closure inputs on the transmitter that are used to control 3A rated relay outputs on the receiver. Both WXL-24 or WXL-900 models are available with 1, 2 or 4 control lines. The control inputs are activated with any non-powered dry-contact switch, or relay contacts in an automated control system (such as a PLC). Units Feature NEMA 4, 4X outdoor rated enclosures with stainless steel mounting feet and water-tight cable glands for wire entree. Transmitters and Receivers are sold as a matched set that are factory programmed. Users requiring more than one transmitter to control multiple receivers, or multiple transmitters to control one receiver must contact our factory to place a custom order.

## 2.2 Available Models

### 2.4 GHz Models (Max Range 1 Mile)

Model Number	Description	Control Lines
WXL-24-1	Wireless Transmitter/Receiver Set (USA/CANADA)	1
WXL-24-2	Wireless Transmitter/Receiver Set (USA/CANADA)	2
WXL-24-4	Wireless Transmitter/Receiver Set (USA/CANADA)	4

### 900 MHz Models (Max Range 6 Miles)

Model Number	Description	Control Lines
WXL-900-1	Wireless Control Transmitter/Receiver Set (USA/CANADA)	1
WXL-900-2	Wireless Control Transmitter/Receiver Set (USA/CANADA)	2
WXL-900-4	Wireless Control Transmitter/Receiver Set (USA/CANADA)	4

## 2.3 Optional Items

Model Number	Description
DRWC-24-LRANT	2.4 GHz Long Range Antenna Set
DRWC-900-LRANT	900 MHz Long Range Antenna Set
WXL-SOLAR-KIT	Solar Power Kit (for transmitter or receiver)

## Section 3 Specifications

### 3.1 Specifications

**Models:** WXL-24

**Radio Frequency:** ISM 2.4 GHz

**RF Power Output:** 63mW

**RF Data Rate:** 250 kbps

**Regulatory:** FCC Part 15 Compliance (No license required)

**Control Lines:** (see model chart)

**Receive Sensitivity:** -100 dBm

**Antenna Connection:** RP-SMA

**Antennas:** 5dbi, Omni-directional (Included)

**Transmit/Receive Distance:**

Indoor/Urban 200ft, Outdoor Line-of-site 600ft (with included antenna set)

Indoor/Urban 500ft, Outdoor Line-of-site 1 Mile (with optional antenna set)

**Transmitter/Receiver Code Matching:** Factory set

**Wire Connection:** Terminal Blocks, 14-24AWG

**Switch Input:** Non-powered, Dry-contact only.

**Receiver Control Output:** Relay, 3A 250V Max

**Operating Temperature:** -22 to 130 °F (-30 to 54 °C)

**Operating Power:** Transmitter - 11-14V DC @ 3W max, Receiver - 11-14V DC @ 6W max

**Enclosures:** NEMA 4, 4X, ABS/PC Blend Plastic (6" x 6" x 4")

**Models:** WXL-900

**Radio Frequency Band:** 902 MHz to 928 MHz

**RF Power Output:** 100mW

**RF Data Rate:** 10 kbps

**Regulatory:** FCC Part 15 Compliance (No license required)

**Control Lines:** 1, 2 or 4 (see model chart)

**Receive Sensitivity:** -106 dBm

**Antenna Connection:** RP-SMA

**Antennas:** 7dbi, Omni-directional (Included)

**Transmit/Receive Distance:**

Indoor/Urban 1000ft, Outdoor Line-of-site 3 Miles (with included antenna set)

Indoor/Urban 1600ft, Outdoor Line-of-site 6 Miles (with optional antenna set)

**Transmitter/Receiver Code Matching:** Factory set

**Wire Connection:** Terminal Blocks, 14-24AWG

**Switch Input:** Non-powered, Dry-contact only.

**Receiver Control Output:** Relay, 3A 250V Max

**Operating Temperature:** -22 to 130 °F (-30 to 54 °C)

**Operating Power:** Transmitter - 11-14V DC @ 3W max, Receiver - 11-14V DC @ 6W max

**Enclosures:** NEMA 4, 4X, ABS/PC Blend Plastic (6" x 6" x 4")

## 3.2 Environmental Operating Conditions

This product has been designed to provide performance and durability over its life time. To keep this product working correctly it should be handled with care and only operated within the following recommended environmental operating conditions.

- An ambient operating temperature range of -22 to 130 °F (-30 to 54 °C)
- A relative humidity of 0-90% Non-condensing
- Enclosures are NEMA 4, 4X rated.

## 3.3 Regulatory Approvals, Location Use & Export Compliance

### REGULATORY APPROVALS

Models: WXL-24

**FCC (USA):** OUR-XBEEPRO

**IC (Canada):** 4214A-XBEEPRO

Models: WXL-900

**FCC (USA):** MCQ-XBEEEXSC

**IC (Canada):** 1846A-XBEEEXSC

The enclosed device complies with Part 15 of the FCC Rules. Operation is subject to the following two conditions: (1.) this device may not cause harmful interference and (2.) this device must accept any interference received, including interference that may cause undesired operation.

### Statement of CE Conformity

Imagine Instruments LLC is committed to compliance with the laws and regulations in each country into which we ship our products. Please contact us to learn the current status of CE compliance for this product.

### Location Use

Standard models of this product are limited to the sale and use in USA and Canada only. Additional models are available for use in Europe (EU), Australia, New Zealand and Japan. Please contact us for model number and availability.

### Export Compliance Policy

Customer shall not, directly or indirectly, export, re-export, transfer, furnish or ship products in violation of any applicable export control laws or regulations of any country having jurisdiction over the products, including any and all US law or US Government export controls. Customer agrees, at Customer's own expense, to comply with all applicable export laws and will, in accordance with the indemnification provisions of these Terms and Conditions, indemnify, defend and hold Imagine Instruments LLC, its officers, owners, agents and employees harmless from any claim against Imagine Instruments LLC due to Customer's violation or alleged violation of any export laws.



## Section 4 Installation

### 4.1 General Guidance

Your wireless control system must be installed and maintained as described in this guide to ensure reliable safe operation. Confirm the voltage and current draw of your connected load to the control output is consistent with the design specifications of this product and your application will not exceed the maximum load capacity listed.

### 4.2 Mounting and Area Environment

This product has been designed for indoor or outdoor use. Insure that the unit has enough area for proper antenna positioning. See below.

**\*\*\*\*\* CAUTION \*\*\*\*\***

**Never operate this product in areas where flammable liquids, gases or any other flammable materials are or might be present.**

### 4.3 Antenna Installation & Positioning

Proper antenna installation and positioning is important and will allow you to achieve maximum performance and distance between your transmitter and receiver unit. This will reduce the possibility of a lost connection during operation.

#### Antenna Basics

When installing your transmitter and receiver it is important to install both units in such a way as to optimize the position of both antennas within what's known as the "Fresnel Zone". A Fresnel Zone can be thought of as a football shaped invisible tunnel between two antennas that provides an optimum path for the RF signals between your transmitter and receiver.

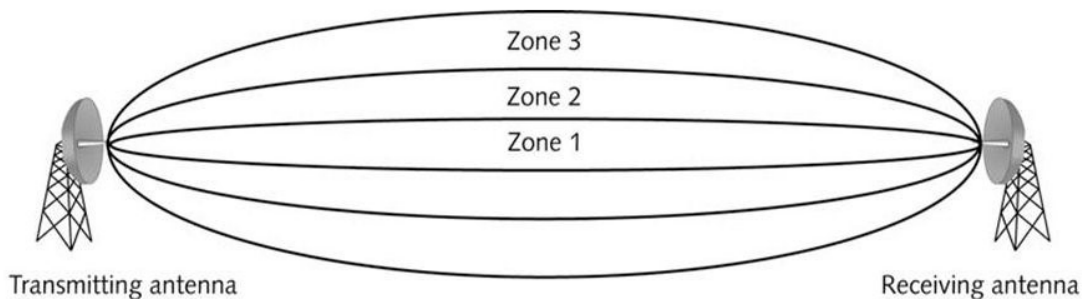

Figure 1. The "Fresnel Zone"

Fresnel created a calculation on how out of phase the wave would be between the transmitter and the receiver. The Fresnel zone is a 3-D cylindrical ellipse shape (like a football) and is made up of multiple zones, Zone 1 being the strongest area for signal strength, Zone 2 being the weaker, Zone 3 being weaker still and so on. There are many Fresnel zones, but only the first 3 have the any major effects on signal strength. Phase cancelling effect in even numbered zones have the maximum effect, while in zones with odd numbers can have a positive effect to signal strength.

So, to maximize the signal strength at the receiver, you want to minimize the any out of phase signals from reaching the receiving end by making sure the strongest signals do not bump into any obstacles. The general rule of thumb is that the 1st Fresnel zone must be 60% clear of obstruction from the center line of sight to the outer boundary of the 1st Fresnel zone to maintain a good connection.

To achieve maximum distance, the path in which the RF signals travel must be free of all obstructions. Obstacles in the path will decrease the transmit/receive distance. Also, if the antennas are mounted too low to the ground, most of the Fresnel zone ends up being obstructed by the earth resulting in significant reduction in transmit/receive distance. Your antennas should be mounted as high off the ground as possible. A minimum of at least 8-9 feet is recommended.

It is important to understand that your application environment may change over time due to new equipment, buildings or other RF equipment being installed. There can also be change within your building such as new construction, etc. If new obstacles are added between your switch transmitter and relay receiver you may need to move and reposition your antennas.

#### 4.4 Connecting Your Antennas

Your control system has been shipped to you with standard antennas. In some difficult installations you may wish to place a remote antenna farther away to maximize transmission range to the receiver. A remote antenna kit option can be ordered that include an antenna extension cable and antenna mounting bracket. Please note that very long antenna extension cables will always add loss to the signal strength. The longer the cable the more signal will be lost over the cable. Because of this the length of the cable should be kept as short as possible. Use of any other antenna then what's supplied with your system or what's available as an option may void FCC and IC regulatory compliance.

#### 4.5 Antenna Placement (Standard Omni Antennas)

##### Vertical Antenna Placement

If the antenna for one of your units is mounted in a vertical position you should mount the antenna of the opposing unit in the same polarization.



Figure 2. Vertical Example with Standard Antennas

## Horizontal Antenna Placement

If the antenna for one of your units is mounted in a horizontal position you should mount the antenna of the opposing unit in the same polarization.

### 4.6 Antenna Placement (Optional Yagi Antennas)

#### Horizontal Antenna Placement

The optional long-distance Yagi antennas must be mounted in the horizontal position as shown in the picture below. Antennas should be mounted pointed at each other.

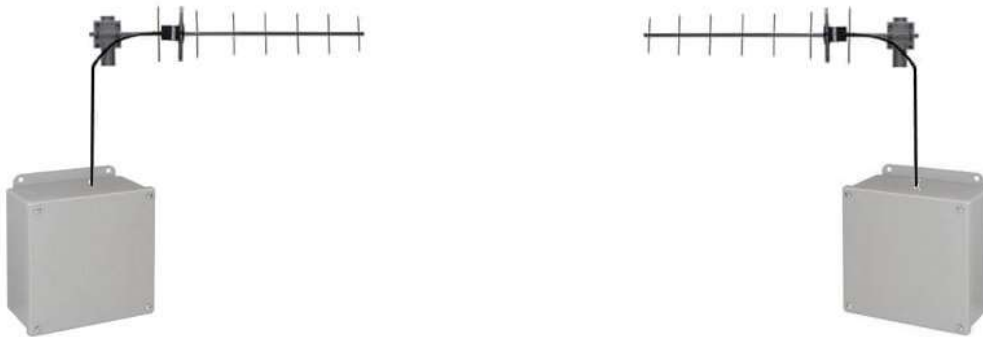

Figure 3. Horizontal Antenna Example

## Section 5 Transmitter/Receiver Features & Settings

### 5.1 Switch Transmitter Features

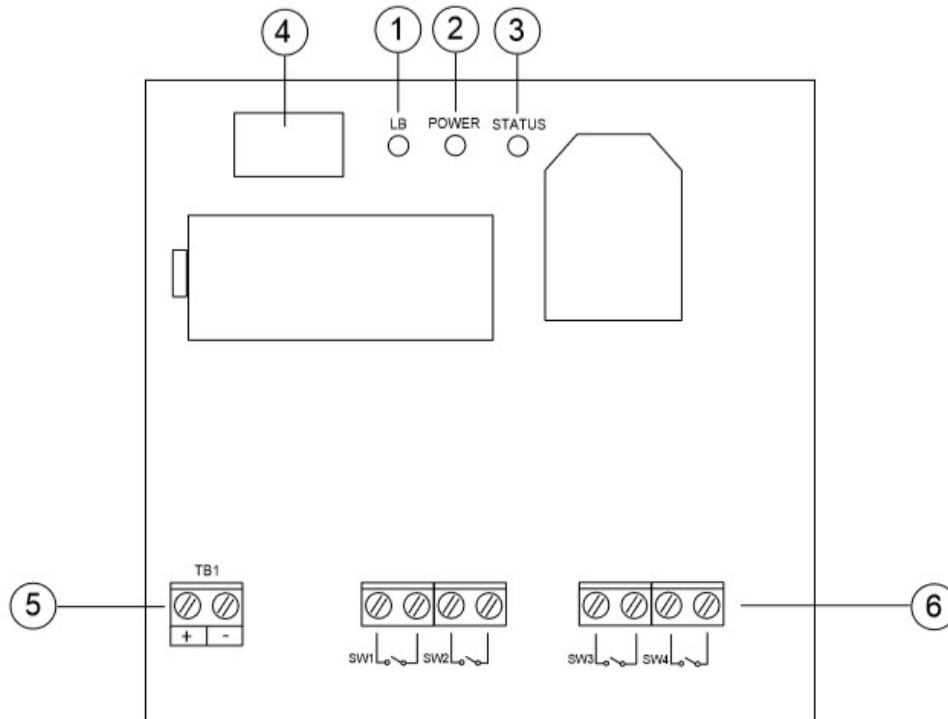

Figure 4. Switch Transmitter Board Features

#### 1. LB (Low Battery/Low Power) Red LED

LED will continuously blink when power connected to the board on terminal block TB1 drops below the required minimum operating voltage of 11V DC.

#### 2. POWER (System Power) Blue LED

LED will be illuminated when the system is powered correctly.

#### 3. STATUS (Radio System Status) Yellow LED

LED will be illuminated and blinking when radio is working correctly.

#### 4. SW1 (Switch)

Not used on transmitter

#### 5. TB1 (Power Connection)

Power is connected to terminal block TB1. The board operates on 11-14V DC. Either a 12V Battery or DC Power Supply can be used.

#### 6. TB3, TB4, TB6, TB7 (Switch Connections)

Dry-contact (non-powered) switches are connected to these terminal blocks to activate the relays on the receiver board.

## 5.2 Relay Receiver Features

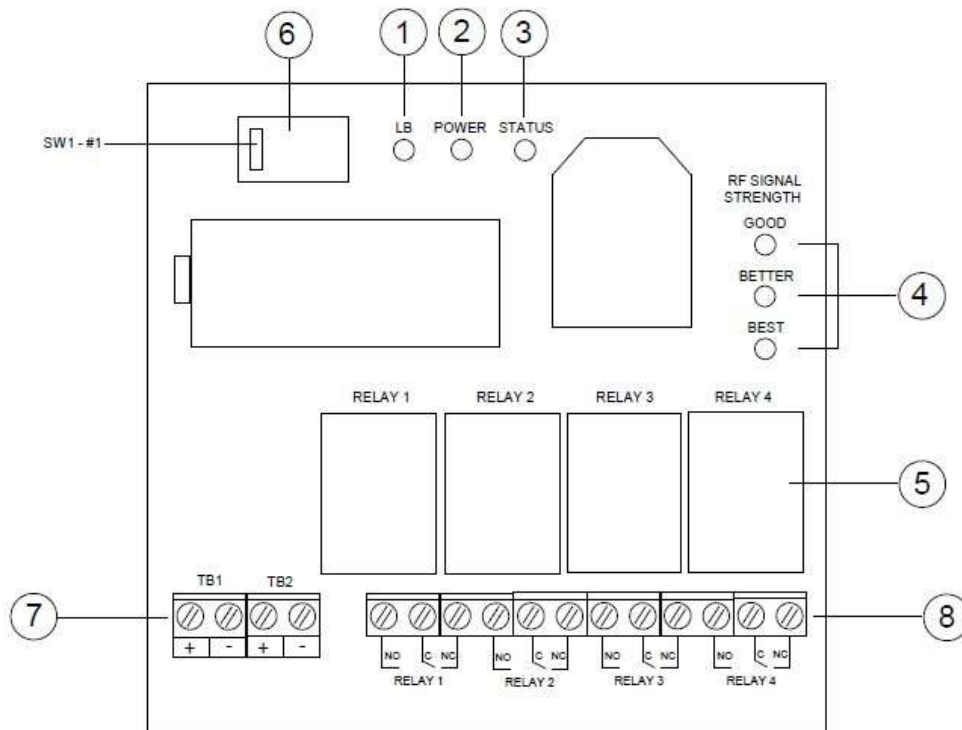

Figure 5. Relay Receiver Board Features

### 1. LB (Low Battery/Low Power on Transmitter Board) Red LED

LED will continuously blink when power connected to the transmitter board drops below the required minimum operating voltage of 11V DC.

Or

LED will come on steady and stay illuminated to alert that either the transmitter board has lost power, or that the radio signal has been lost and there is no communication between boards.

### 2. POWER (System Power) Blue LED

LED will be illuminated when the system is powered correctly.

### 3. STATUS (Radio System Status) Yellow LED

LED will be illuminated and blinking when radio is working correctly

### 4. RF SIGNAL STRENGTH Meter (Good, Better, Best) Green LEDs

Set of three green LEDs that indicate how good your radio signal connection is. Monitor this when installing antennas to achieve the best RF link between boards as possible.

## 5. RELAYS (1, 2, 3, 4)

Control relays are SPDT Form C. Load connected to relays is 3 Amps, 240V Max. This is limited by the board traces and the terminal block rating. A load greater than 3A will damage the board.

## 6. SW1 (Switch) Radio Signal Lost Options for Output Relays

Switch position #1 OFF (Down) – Relays turn off if radio signal is lost.

Or

Switch position #1 ON (UP) – Relays stay in current state if radio signal is Lost.

## 7. TB1/TB2 (Power Connection & Alarm Connection)

Power is connected to terminal block TB1. The board operates on 11-14V DC.

A DC Power Supply will be needed.

TB2 provides a 5V DC output signal whenever radio communication is lost between boards.

This output can be used to activate an alarm device. Max load is 40mA.

## 8. TB3, TB4, TB5, TB6, TB7, TB8 (RELAY CONNECTIONS)

Relay connections are marked NO (Normally Open), NC (Normally Closed) and C (Common). When the relay is not activated by a switch closure on the transmitter board the NO terminal does not provide a path to the C terminal. When the relay is in this "off" state there is a direct connection between the NC terminal and the common terminal. When the relay is activated by a switch action on the transmitter board the relay changes state. The NO terminal will now be connected to the C terminal and the NC terminal will no longer be connected to the C terminal.

## Section 6 Setup & Wiring

### 6.1 Powering Your Unit



**WARNING: Electrical Shock Hazard**

All wiring should be done by a qualified suitably trained person only.



**CAUTION:** Insure all control output connections are well insulated.

**Note:** Fusing is recommended in series with control outputs.

### 6.2 Power Supply Wiring

Both the transmitter and receiver operate on 11-14V DC. For the transmitter a power supply with a 3 Watt or higher operating capacity is sufficient. For the receiver a power supply with a 6 Watt or higher operating capacity is required. Power to operate both the transmitter and receiver are connected to the Terminal Block marked TB1. See example here.

#### Battery Power with Solar Charging Operation

Your switch transmitter board can also be powered with a 12V DC rechargeable deep-cycle battery, solar panel and solar charge controller. The solar panel and charge controller will re-charge the battery each sunny day. This setup will provide uninterrupted power to your switch transmitter.

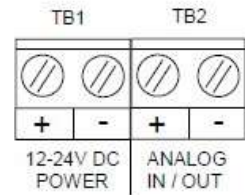

Figure 6. TB1 Power Connection

## Section 7 – General Operation

### 7.1 Basic System Operation

#### General Description

Our Din-rail Wireless Remote-Control System allows for remotely activating equipment using license free radio communication. Contact closure inputs are used to control outputs on the opposing unit within the system. Inputs are activated with dry-contact manual switches or connected to a PLC for automated control.

#### If RF Signal is Lost or Transmitter Board Loses Power

The receiver board has supervisory features to alert is RF signal communication is lost or if the transmitter board loses power. The following describes these features...

#### SW1 - Switch position #1 OFF (Down)

- A. Relays will immediately turn to the "OFF" non-active state.
- B. The Red (LB) LED on the board will turn on.
- C. A 5V DC output will be available on terminal block TB2 to activate an alarm. 40mA Max load.

#### SW1 - Switch position #1 ON (UP)

- A. Relays will remain in the current state until they receive a new "change state" command from the transmitter.
- B. The Red (LB) LED on the board will turn on.
- C. A 5V DC output will be available on terminal block TB2 to activate an alarm. 40mA Max load.

#### If Low Power condition occurs on the Transmitter Board

- A. The Red LED (LB) on both the Transmitter and Receiver boards will continuously blink until the power supply is increased above 11V DC.

### 7.2 Factory Settings

Units are sold and shipped as a "Matched Pair". Factory code setting insures matched pair units only communicate with each other. Multiple matched pair systems can be used within the same area without interfering with each other. Each unit receives a factory code that is printed on the product label.



## Section 8 – Installation & Setup

### 8.1 Connecting Switches to Transmitter Board

On models WXL-24 or WXL-900 there are switch inputs on only one side of the system. Switch inputs are only on what we call “the Transmitter”. The switch inputs connected to the transmitter must be “dry-contact type. That means you do not need to supply any type of power on the input circuit. The input is a two-wire connection that can be a simple mechanical switch, a level or flow switch, or the contacts of a relay. If you apply power to any of the switch inputs, you will damage the unit.

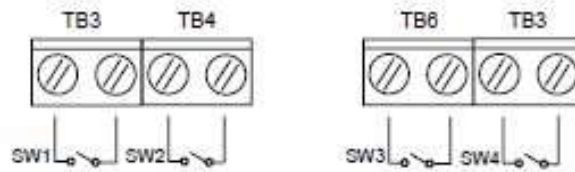

Figure 7. Switch Connections

### 8.2 Control Relay Output Connections

On models WXL-24 or WXL-900 there are control relays on only one side of the system. Control relays are only on what we call “the receiver”. The control relays are what’s known as “Form C” type. The relays are SPDT type that are rated up to 3A 250V. If you apply a load greater than what’s stated in the specifications listed in this manual, you will permanently damage your unit.

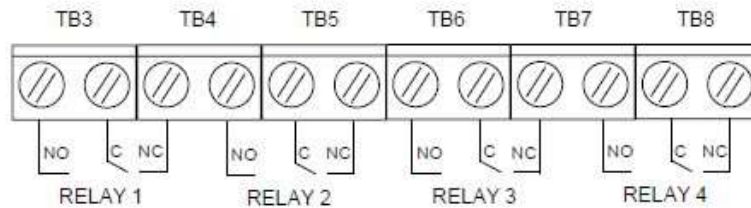

Figure 8. Relay Output Connections

### 8.3 RF Signal Strength Indicator

The receiver board features 3 green LEDs that form a radio signal strength indicator. The indicator is used during installation to optimize the radio signal connection between the transmitter and receiver boards. Having all 3 LEDs illuminated is not mandatory for good system operation. Having only one or two of the LEDs illuminated is sufficient for reliable communication between boards.



Figure 9. Signal Meter

## 8.4 RF Signal Loss Alarm Output

If the receiver board loses radio communication with the Transmitter board a 5V DC alarm signal is produced on terminal block TB2. This voltage output can be used to trigger an alarm device to alert that the receiver is no longer receiving commands from the transmitter board. The alarm voltage will drop to zero volts when the system is back to normal status. Maximum load that the 5V output can handle is 40mA.

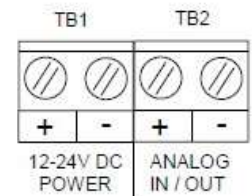

Figure 10. Alarm Connection

## Section 9 Maintenance

### 9.1 Maintenance

This product has been designed to be maintenance free during its life time. Periodic inspection should take place to ensure that the following has not occurred during use:

- Insure the unit is still mounted securely and has not become loose due to vibration.
- With power removed Insure all wiring connection are still tight and well insulated.
- Insure the unit is free of moisture, grease, dirt or any other foreign material.

If the outside of this product has become soiled, it may be wiped clean with a lightly damp cloth.

## Section 10 Warranty & Liability

### 10.1 Warranty/Product Returns

Imagine Instruments LLC as expressed as “Company” in this document.

All Product orders are subject to written acceptance by Company by a duly authorized agent of Company. This product is covered by a Limited Warranty for a period of 1 year from the date of purchase which applies to defective Products only. COMPANY EXPRESSLY DISCLAIMS ALL OTHER WARRANTIES OF ANY KIND, WHETHER EXPRESS OR IMPLIED, INCLUDING, BUT NOT LIMITED TO, IMPLIED WARRANTIES OF MERCHANTABILITY AND FITNESS FOR A PARTICULAR PURPOSE. Company will only accept the return of defective Products. Such returns must be pre-approved by Company in writing and an RMA (Return Material Authorization) number must be issued by Company before Company will accept such return. Return shipments not pre-approved by Company will be refused. Company will inspect pre-approved returns to determine whether they are defective, which determination by Company is final. Products must be returned in the same or equivalent container and packaging materials in which they were originally shipped. Customer retains title to any Products returned. Return freight cost is the responsibility of Customer. If Company determines a Product is defective, it may repair or replace the defective Product.

### 10.2 Limitation of liability

COMPANY'S LIABILITY ON ANY CLAIM OF ANY KIND, INCLUDING NEGLIGENCE, FOR ANY LOSS OR DAMAGE ARISING OUT OF, CONNECTED WITH, OR RESULTING FROM THE MANUFACTURE, SALE, DELIVERY, RESALE, REPAIR OR USE OF ANY PRODUCTS COVERED BY OR FURNISHED HEREUNDER, SHALL IN NO CASE EXCEED THE LESSER OF THE COST OF REPAIRING OR REPLACING PRODUCTS FAILING TO CONFORM TO THE WARRANTIES CONTAINED HEREIN, IF ANY, OR THE PRICE OF THE PRODUCTS OR PART THEREOF WHICH GIVES RISE TO THE CLAIM. IN NO EVENT WILL COMPANY BE LIABLE FOR ANY DIRECT, INDIRECT, INCIDENTAL, SPECIAL OR CONTINGENT DAMAGES,

INCLUDING, BUT NOT LIMITED TO, DAMAGES FOR LOSS OF PROFITS, GOODWILL, USE OR OTHER INTANGIBLE LOSS (EVEN IF COMPANY HAS BEEN ADVISED OF THE POSSIBILITY OF SUCH DAMAGES), RESULTING FROM: (I) THE USE OR THE INABILITY TO USE PRODUCTS PURCHASED FROM COMPANY; (II) THE COST OF PROCUREMENT OF SUBSTITUTE PRODUCTS RESULTING FROM ANY PRODUCTS PURCHASED OR OBTAINED FROM COMPANY; OR (III) ANY OTHER MATTER RELATING TO PRODUCTS PURCHASED FROM COMPANY.

Additional "Terms & Conditions" apply. Please visit [www.imagineinstruments.com](http://www.imagineinstruments.com) to read the complete Imagine Instruments LLC "Terms & Conditions" statement.

## Section 11 Repair & Service

### 11.1 Repair / Service

A RMA (Return Merchandise Authorization) number must be obtained before the product is returned to us. Please call us to obtain an RMA number. Any product received without a RMA will be returned to the customer. The cost and method of shipping the product back to us is the sole responsibility of the customer. We recommend a track-able form of shipping to guarantee your package arrives to us. If a package is sent without proof of delivery, Imagine Instruments LLC is not responsible for proving receipt of the package.

All products come with a minimum one-year warranty unless otherwise noted on the products data sheet. Warranty replacements must have an RMA issued and be returned to imagine Instruments LLC prior to us sending the replacement. The return cost of insurance and shipping is the sole responsibility of the customer. Imagine Instruments LLC will pay for the return shipping of the replacement and chooses the method of delivery.

After receiving your RMA number, please ship your unit to the Product Return address listed in section 11.2 below. Make sure you write the RMA number on the mailing label.

### 11.2 Contact Information

General Mail:

Imagine Instruments LLC  
4500 Williams Drive  
Ste 212-318  
Georgetown, TX 78633

Phone Numbers:

Local: (512) 778-6850  
Toll Free: (855) 574-6243

Email:

General Information/ Customer Service – [info@imagineinstruments.com](mailto:info@imagineinstruments.com)  
Sales Department – [sales@imagineinstruments.com](mailto:sales@imagineinstruments.com)